



PNOZmulti Installation Manual

PILZ
THE SPIRIT OF SAFETY

- ▶ Configurable control systems PNOZmulti 2
- ▶ Configurable compact control systems PNOZmulti Mini
- ▶ Configurable safety systems PNOZmulti

This document is a translation of the original document.

All rights to this documentation are reserved by Pilz GmbH & Co. KG. Copies may be made for internal purposes. Suggestions and comments for improving this documentation will be gratefully received.

Source code from third-party manufacturers or open source software has been used for some components. The relevant licence information is available on the Internet on the Pilz homepage.

Pilz®, PIT®, PMI®, PNOZ®, Primo®, PSEN®, PSS®, PVIS®, SafetyBUS p®, SafetyEYE®, SafetyNET p®, the spirit of safety® are registered and protected trademarks of Pilz GmbH & Co. KG in some countries.



SD means Secure Digital

Section 1	Introduction	5
	1.1 Validity of the documentation	5
	1.2 Definition of symbols	5
Section 2	Safety	7
	2.1 General safety guidelines	7
	2.2 Use of qualified personnel	7
	2.3 Safety during installation	7
	2.3.1 Power supply	7
	2.3.2 Installation	8
	2.3.3 Chip card	8
Section 3	Electromagnetic compatibility (EMC)	10
	3.1 Overview	10
	3.2 Making the installation EMC-compliant	11
	3.2.1 Connecting the earth cables	11
	3.2.2 Cable routing	11
	3.2.3 Connecting the fieldbuses	12
	3.2.4 Equipotential bonding	12
	3.2.5 Shielding	12
	3.2.6 Suppression on inductive loads	13
	3.2.7 Lighting in the control cabinet	13
	3.3 Testing the EMC-compliance of an installation	14
Section 4	Installation	16
	4.1 Control cabinet installation	16
	4.1.1 General installation guidelines	16
	4.1.1.1 Positioning of units	16
	4.1.2 Mounting distances	17
	4.2 Install the control system PNOZmulti	18
	4.2.1 Install base unit without expansion module	18
	4.2.2 Connect the base unit and expansion modules	18
	4.3 Install the control system PNOZmulti Mini	19
	4.3.1 Install base unit without expansion module	19
	4.3.2 Connect the base unit and expansion modules	20
	4.4 Install the control system PNOZmulti 2	21
	4.4.1 Install base unit without expansion module	21
	4.4.2 Connecting the base unit and expansion modules	22
Section 5	Connecting the Control System PNOZmulti	23
	5.1 General wiring guidelines	23
	5.2 Supply voltage	23
	5.3 Earthing	24
	5.4 Cable requirements	24
	5.5 Terminals	25
	5.6 Connecting safety inputs and outputs	25
	5.7 Example of EMC-compliant wiring	26

5.8	Analogue input module	26
5.9	Motion monitoring modules	27
5.10	Connection example: analogue input module and speed monitor	29
5.11	Fieldbus modules	31
5.12	Link modules	31
5.13	Cascading	32
5.13.1	System requirements	33
5.13.2	Series connection	33
5.13.3	Tree structure	34
5.13.4	Supply voltage for the cascaded units	35
5.13.5	Installing the cascaded units	35
5.13.6	Wiring	36

1 Introduction

1.1 Validity of the documentation

This documentation is intended for instruction and should be retained for future reference.

This installation manual contains all the information you need to install the configurable small control systems PNOZmulti.

Please also refer to the following documents:

- ▶ The respective operating manuals contain a description of the units' functionality and guidelines on their operation.
- ▶ The document "PNOZmulti System Expansion" contains details of the maximum system expansion.

This documentation is valid for the configurable small control systems PNOZmulti:

- ▶ Configurable control systems PNOZmulti 2
- ▶ Configurable compact control systems PNOZmulti Mini
- ▶ Configurable safety systems PNOZmulti.

The documentation is valid until new documentation is published.

1.2 Definition of symbols

Information that is particularly important is identified as follows:



DANGER!

This warning must be heeded! It warns of a hazardous situation that poses an immediate threat of serious injury and death and indicates preventive measures that can be taken.



WARNING!

This warning must be heeded! It warns of a hazardous situation that could lead to serious injury and death and indicates preventive measures that can be taken.



CAUTION!

This refers to a hazard that can lead to a less serious or minor injury plus material damage, and also provides information on preventive measures that can be taken.

**NOTICE**

This describes a situation in which the product or devices could be damaged and also provides information on preventive measures that can be taken. It also highlights areas within the text that are of particular importance.

**INFORMATION**

This gives advice on applications and provides information on special features.

2 Safety

2.1 General safety guidelines

Please note the following general safety guidelines:

- ▶ Ensure VDE, local and national regulations are met, especially those relating to safety. The relevant safety regulations for the respective application must also be met.
- ▶ The product is designed exclusively for use in an industrial environment. It is not suitable for use in a domestic environment, as this can lead to interference. Additional suppression measures may be required.
- ▶ The deciding factors in how to use the device are the requirements of the relevant certification body (e.g. BG or TÜV).
- ▶ In particular please observe the wiring regulations.
- ▶ If the devices are altered in any way, such as exchanging a component or carrying out soldering work, the guarantee, and any approval, will be rendered invalid.
- ▶ Devices must be disposed of properly when they reach the end of their service life.

2.2 Use of qualified personnel

The products may only be assembled, installed, programmed, commissioned, operated, maintained and decommissioned by competent persons.

A competent person is someone who, because of their training, experience and current professional activity, has the specialist knowledge required to test, assess and operate the work equipment, devices, systems, plant and machinery in accordance with the general standards and guidelines for safety technology.

It is the company's responsibility only to employ personnel who:

- ▶ Are familiar with the basic regulations concerning health and safety / accident prevention
- ▶ Have read and understood the information provided in this description under "Safety"
- ▶ And have a good knowledge of the generic and specialist standards applicable to the specific application.

2.3 Safety during installation

2.3.1 Power supply

The control system requires a 24 VDC supply. Check that the external power supply provides this voltage.

The tolerance of the supply voltage must comply with the technical details. Safe operation cannot be guaranteed outside this range.

Protect the external power supply by fitting a fuse between the external power supply and the control system. The size of the fuse will depend on the specification of the external power supply, the cable cross section and on local regulations.

**WARNING!****Risk of electrocution!**

Safe electrical isolation must be ensured for the external power supply that generates the supply voltage. Failure to do so could result in electric shock.

The power supplies must comply with EN 60950-1:2006/A11:2009, EN 61558-2-6:11/1997.

**WARNING!****Risk of electrocution!**

When voltage is applied, contact with live components could result in serious or even fatal injury from an electric shock.

If voltages higher than 50 VAC or 120 VDC are connected to the control systems PNOZmulti or PNOZmulti Mini, e.g. to switch contacts on relay modules, please note the following:

- Specific accident prevention regulations apply.

2.3.2

Installation

Please note:

- ▶ The control systems should be installed in an enclosure, e.g. control cabinet.
- ▶ The control cabinet must conform to the protection class required for the environment.
- ▶ Please refer to the technical details of the relevant devices when installing them in the control cabinet.
- ▶ Ensure there is sufficient ventilation to prevent heat building up within the control cabinet. Monitor the ambient temperature of 0 ... 60 °C.
- ▶ In extreme ambient conditions, additional measures such as control cabinet air conditioning may be required in order to keep within the prescribed value range.

2.3.3

Chip card

The base units for the PNOZmulti and PNOZmulti Mini and the base units PNOZ m B0 from the PNOZmulti 2 range have a chip card for saving and downloading projects.

**NOTICE**

The chip card contact is only guaranteed if the contact surface is clean and undamaged. For this reason please protect the chip card's contact surface from

- Contamination
- Contact
- Mechanical impact, such as scratches.

The base units PNOZ m B1 have a USB memory for saving and downloading projects.

3 Electromagnetic compatibility (EMC)

3.1 Overview

The PNOZmulti systems are designed for use within an electromagnetic industrial environment. To ensure electromagnetic compatibility the correct procedures must be carried out during installation.

A device is electromagnetically compatible if

- ▶ It functions without error in a given electromagnetic environment.
- ▶ It does not adversely affect its own environment.

Electromagnetic interference can reach the devices through:

- ▶ Fields
- ▶ Power supplies
- ▶ Earth cabling
- ▶ Bus connections
- ▶ Interfaces
- ▶ Input and output cables

The interference can be transferred from the source to the receiver (interference sink) via the coupling routes.

Interference reaches the interference sink (e.g. the control system devices) in various ways:

- ▶ DC coupling:
DC coupling occurs if the source and sink of interference have common cable connections. The common cable presents complex resistances, inducing potential differences.
 - Typical sources of interference are switches/relays, running motors or varying potentials for other systems on the same power supply.
- ▶ Capacitive (electrical) coupling
A different potential between the source and interference sink (e.g. two cables) creates an electrical field. Coupling is proportional to the rate of voltage change.
 - Typical sources of interference are contactors, static discharge, parallel signal cables.
- ▶ Inductive (magnetic) coupling
A live cable produces a magnetic field which also surrounds adjacent cables. Interference voltage is induced. Coupling is proportional to the rate of current change.
 - Typical sources of interference are mains cables running in parallel, live cables, high frequency cables, inductors, transformers, motors.
- ▶ Electromagnetic coupling
A cable can emit a signal as a radio wave. This wave is then picked up by another cable.
 - Typical sources of interference are transmitters such as radios, sparks from spark plugs, welding equipment, etc.

**NOTICE**

Powerful HF transmitters should only be operated at a distance of more than 0.6 m.

- ▶ **Static discharge:**
Static discharge occurs where there are very high differences in potential between two points. If the two points are brought closer together or if the potential difference is increased, discharges can occur in the air gaps.
 - Typical source of interference: people who are statically charged from a synthetic carpet, for example.

3.2 Making the installation EMC-compliant

3.2.1 Connecting the earth cables

Please note:

- ▶ A conductor cross section of at least 2.5 mm² should be used for the connection to the central earth bar. Connections should be kept as short as possible.
- ▶ Connections to the earth bar should always be in star form.
- ▶ Connect together the 0V connections on all the 24 V power supplies and earth the 0 V mains at a single point, or ensure that measures are in place to monitor for earth faults.
- ▶ Earthed supply voltages offer the best noise immunity.
- ▶ The connection of the 0 V supply to the central earth bar or earth fault monitor must be in accordance with relevant national regulations (such as EN 60204-1, NFPA 79:17-7, NEC: Article 250).
- ▶ Define a central earthing point.
- ▶ Make sure that the control system and motor are earthed correctly.
- ▶ Earth the mounting plate.
- ▶ Connections should be protected from corrosion.
- ▶ Flexible earthing straps should be used on moving earth parts (e.g. machine parts, gates). Ensure these earthing straps are as short and wide as possible.

3.2.2 Cable routing

It is possible to differentiate between cables according to their function. The following groups exist:

- ▶ Group 1: Data and supply lines for DC voltages below 60 V and AC voltages below 25 V
- ▶ Group 2: Data and supply lines for DC voltages from 60 V to 400 V and AC voltages from 25 V to 400 V.
- ▶ Group 3: Supply lines above 400 V

Cabling inside buildings

- ▶ The cable groups listed above should be laid separately.

- ▶ Cables of the same group can be laid within the same cable duct.
- ▶ Cables from group 1 and group 2 should be laid in separate groups or in cable ducts which are at least 10 cm apart.
- ▶ Cables from group 1 and group 3 should be laid in separate groups or in cable ducts which are at least 50 cm apart.
- ▶ Data and signal lines should be laid as close as possible to an earthed surface.

Cabling to open air systems

- ▶ As far as possible use metal conduits. These should be electrically connected and earthed.
- ▶ Ensure there is sufficient protection against lightning by using metal conduits earthed at both ends, or concrete cable ducts with reinforcements connected across the joints.

3.2.3 Connecting the fieldbuses

To connect the available fieldbus systems, please refer to the

- ▶ Operating manual for the respective fieldbus module.
- ▶ Guidelines published by the user group or manufacturer of the respective fieldbus.
- ▶ "Communication interfaces PNOZmulti" document

3.2.4 Equipotential bonding

Potential differences can occur if the devices are connected to different earth or ground connections. Even cable shields that are connected at either end and have different earth connections can cause potential differences. In order to avoid interference, equipotential bonding cables must be installed. Please note:

- ▶ Select a low impedance equipotential bonding cable.
- ▶ Select the following as standard values for the cross section of the equipotential bonding cables:
 - 16 mm² for equipotential bonding cable up to 200 m in length
 - 25 mm² for equipotential bonding cable over 200 m in length
- ▶ If the devices of the control system PNOZmulti are connected with shielded signal cables which are earthed at either end, the impedance is calculated as follows:
 - Impedance equipotential bonding cable = 10 % of shield impedance
- ▶ Use copper or galvanised steel equipotential bonding cable.
- ▶ Connect equipotential bonding cables to the earth bar over as wide a surface area as possible.
- ▶ As short a distance as possible should be kept between the equipotential bonding cable and signal cable.

3.2.5 Shielding

Interference currents must be diverted to cable shields via shield bars.

Please note:

- ▶ Connect the shields with low impedance to the shield bar or earth bar.
- ▶ Use cables with a braided shield, with a minimum coverage of 80 %.

- ▶ When laying cables without equipotential bonding or using foil shields: Connect the shield at one end.
- ▶ If possible, use metal or metallised plugs to connect cables for serial data transfer. Always refer to the regulations relating to the fieldbus systems.
- ▶ If the shield is not to be connected at the end of the cable, it must have no connection to the connector housing.
- ▶ If the shield is to be connected, connect it to the shield bar at the point where the cable enters the cabinet, without making a break in the cable. Use metal cable clamps which cover the shield over a wide surface area. Route the shield as far as the units, but do not connect it to the units.

Digital inputs and outputs do not need shielded cables. However, if the connection cables have a shield, it should be connected at one end.

Analogue inputs and inputs on the incremental encoder on the speed monitors should always be connected using shielded cables.

**INFORMATION**

A connection example is available in the chapter entitled "Connecting the Control System", under "Analogue input module".

3.2.6 Suppression on inductive loads

Adequate protection must be provided for all inductive consumers.

3.2.7 Lighting in the control cabinet

Use low interference panel lighting for inside the control cabinet.

3.3 Testing the EMC-compliance of an installation

You can use the list below to check that the installation of the control systems PNOZmulti and PNOZmulti Mini is EMC-compliant.

Check	Action	Done
Are there areas with a high probability of interference? (e.g. computers running, process control areas, distribution cabinets, cable casing, frequency converters, hand-held radios etc.)	EMC protection in these areas should be planned with particular care.	
Are areas where computers are running or areas such as process control rooms sufficiently shielded from electromagnetic coupling?	If necessary shield the whole area.	
Does the cable layout take into account the principles of EMC compliance?	Some important points: Lay cables close to earth, keep clear of other electrical equipment, keep cables in ducts separate from other parts of the installation, keep cables as short as possible, avoid multiple crossovers	
Is the supply voltage free of interference?	Supplies with interference voltages should be fitted with a mains filter.	
EMC characteristics of individual units / all units tested once installed?	Test EMC characteristics under operating conditions, e.g. while hand-held radios are in use, or HF frequency generators are close by. Test static discharge with operating personnel, test mutual interference between units under different operating conditions.	
Earthed parts connected correctly?	Most important are the connections between the units, racking bars, earth conductors and shield bars; inactive metal parts should be connected over a wide surface area and earthed at a central point; with insulated metal: Remove insulation or use special contact fixings; protect the connection from corrosion; connect the cabinet doors to the body of the cabinet using earthing straps	
Cable groups laid separately?	Separate cables into groups. Supply and signal leads should be laid separately	
Are the shields connected correctly?	Use shielded cables for analogue and data leads; use metallic plugs; connect cable shields to shield bar at point of entry to cabinet; connect cable shields over a wide surface area and with low impedance	
Equipotential bonding carried out?	If the installation extends over a wide area: Equipotential bonding cables should be laid.	
Are inductive loads switched?	Sufficient fuse protection should be provided with inductive loads	

Check	Action	Done
24 VDC power supply?	Power supplies must conform to EN 60742:9/1995, EN 60950-1:2006/A11:2009 or EN 50178: 10/97	
Mains in accordance with TN-S system?	This guarantees that there is no connection between the neutral conductor and protective conductor within the machine. With unbalanced loads, e.g. TN-C systems, currents can be fed back to the source via the PEN conductor and the currents on the PEN are not zero. This can lead to EMC problems.	

4 Installation

4.1 Control cabinet installation

4.1.1 General installation guidelines

Please note during installation:

- ▶ The unit should be installed in a control cabinet with a protection type of at least IP54.
- ▶ Fit the control system to a horizontal mounting rail. The venting slots must face upward and downward. If other mounting positions are used there will be insufficient ventilation.
- ▶ Use the locking element on the rear of the unit to attach it to a mounting rail.
- ▶ In environments exposed to heavy vibration, the unit should be secured against lateral movement by using a fixing element (e.g. retaining bracket or end angle).
- ▶ To comply with EMC requirements, the mounting rail must have a low impedance connection to the control cabinet housing.
- ▶ The coated versions of the PNOZmulti units are suitable for use where there are increased environmental requirements on temperature and humidity. Please refer to the technical details.
- ▶ Note the relevant standards when wiring the control cabinet. For example:
 - DIN EN 61439-1 (VDE 0660-600-1):2012-06 Low-voltage switchgear and controlgear assemblies – Part 1 General rules,
 - DIN EN 61439-2 (VDE 0660-600-2):2012-06 Low-voltage switchgear and controlgear assemblies – Part 2: Power switchgear and controlgear assemblies,
 - DIN EN 60204-1, DIN EN 69439-1,
 - Machinery Directive 2006/42/EC,
 - EMC Directive 2004/108/EC.
- ▶ Please note the guidelines given under [Electromagnetic compatibility](#)  10].

4.1.1.1 Positioning of units

The position of the expansion modules is defined in the PNOZmulti Configurator. The expansion modules are connected to the left or right of the base unit, depending on the type.

- ▶ Install the expansion module in the position in which it is configured in the PNOZmulti Configurator.

For module selection please refer to the online help for the PNOZmulti Configurator

The position of the expansion modules is defined in the PNOZmulti Configurator. The expansion modules are connected to the left or right of the base unit, depending on the type.

Please refer to the document "PNOZmulti System Expansion" for details of the number of modules that can be connected to the base unit and the module types.

4.1.2 Mounting distances

With control cabinet installation it is essential to maintain a certain distance from the top and bottom, as well as to other heat-producing devices (see diagram). The values stated for the mounting distances are minimum specifications.

The ambient temperature in the control cabinet must not exceed the figure stated in the technical details. Air conditioning may otherwise be required.

Mounting distances:

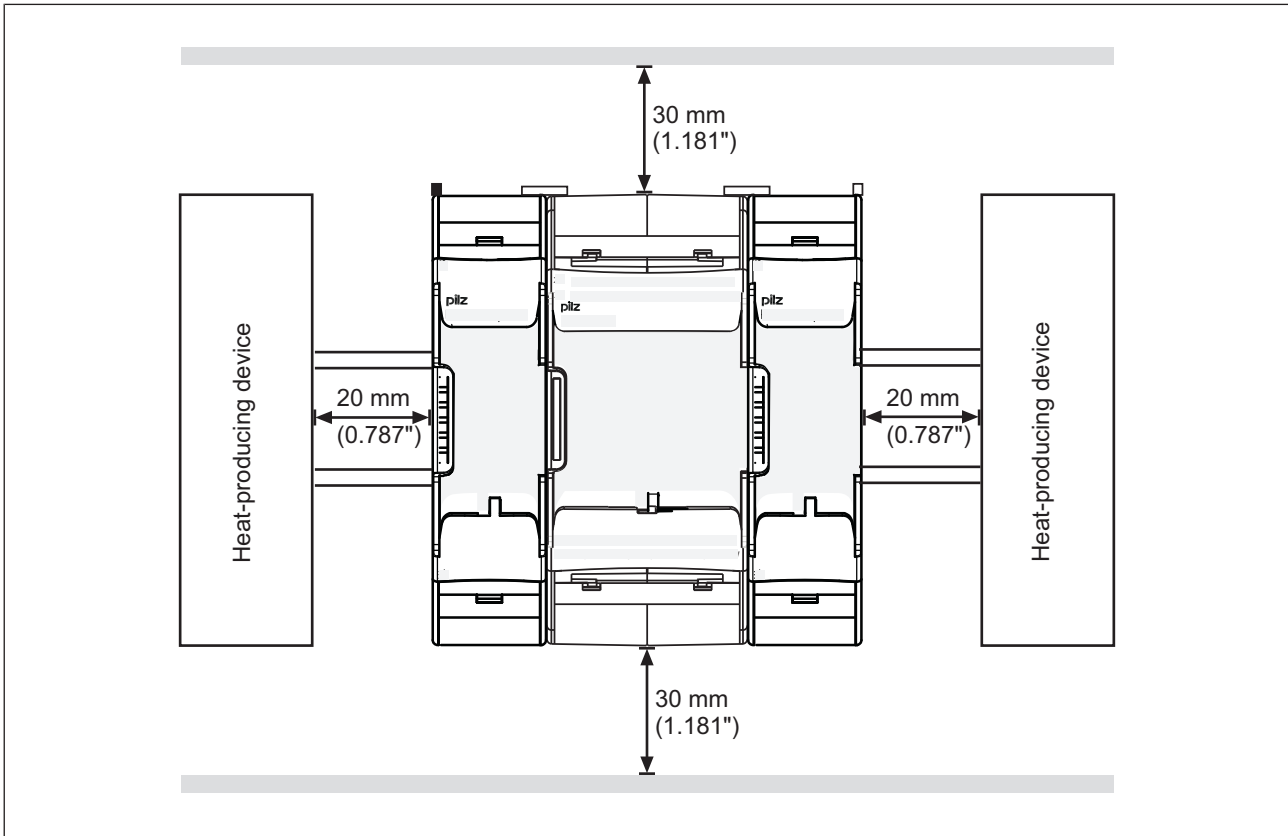

4.2 Install the control system PNOZmulti

4.2.1 Install base unit without expansion module

When installed on its own, a base unit from the configurable control system PNOZmulti must be fitted with a terminator:

- ▶ The terminator must be fitted to the side of the base unit marked "Termination/Link".
- ▶ Do not fit a terminator on the left hand side of the base unit.

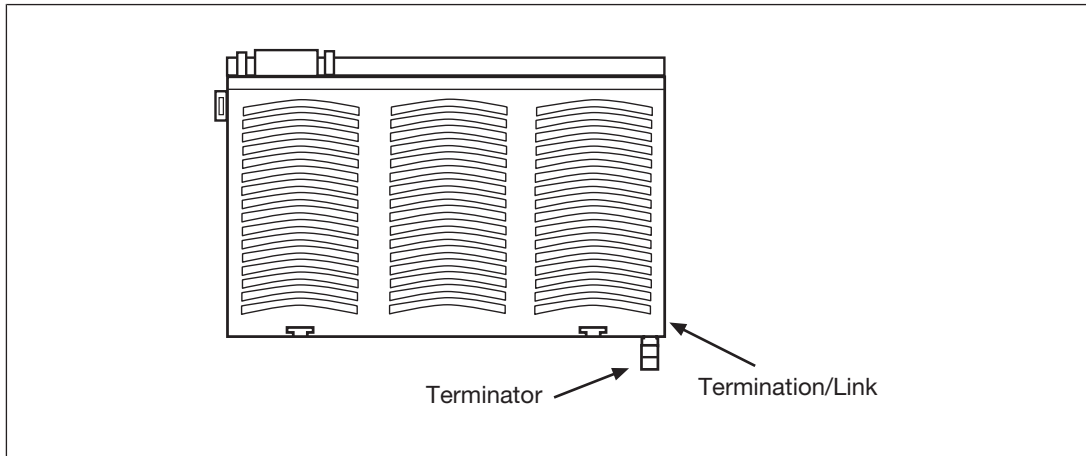

4.2.2 Connect the base unit and expansion modules

The modules are linked via jumpers.

There are 2 pin connectors on the rear of the base unit.

- ▶ Make sure that no terminator is fitted.
- ▶ Connect the base unit, expansion modules and fieldbus module using the jumpers supplied.
- ▶ The terminator must be fitted to the last expansion module to the right of the base unit.
- ▶ A terminator must not be fitted to the last expansion module to the left of the base unit.

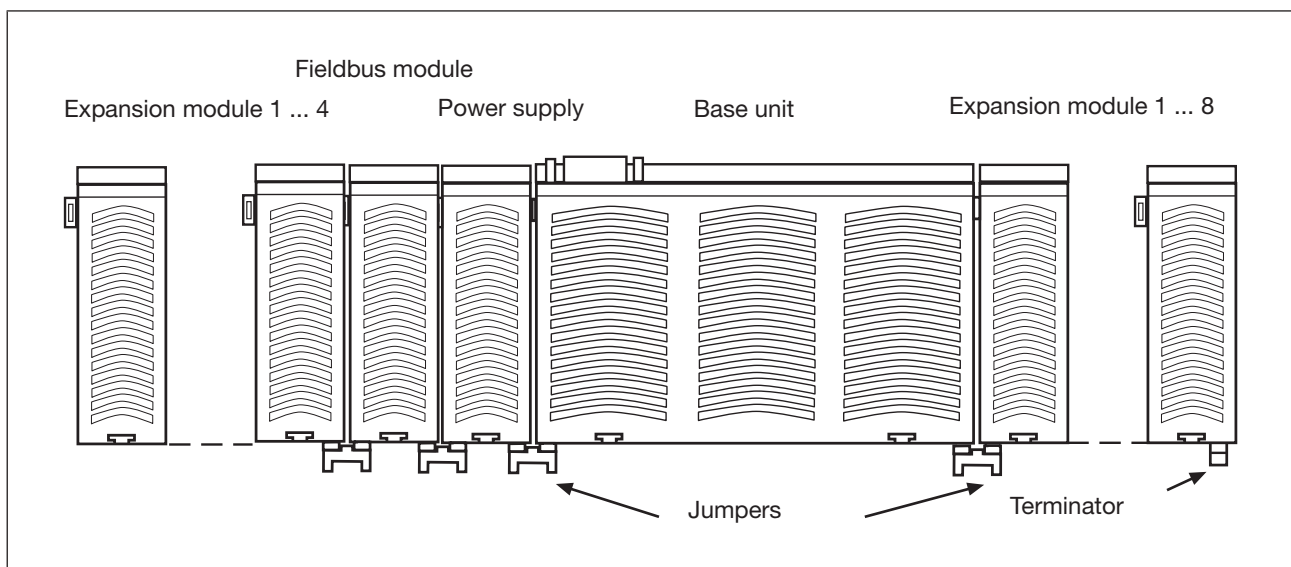

4.3 Install the control system PNOZmulti Mini

4.3.1 Install base unit without expansion module

Make sure that the terminators are inserted on the top left and right of the unit :

- ▶ Left: Black/yellow terminator
- ▶ Right: Yellow terminator

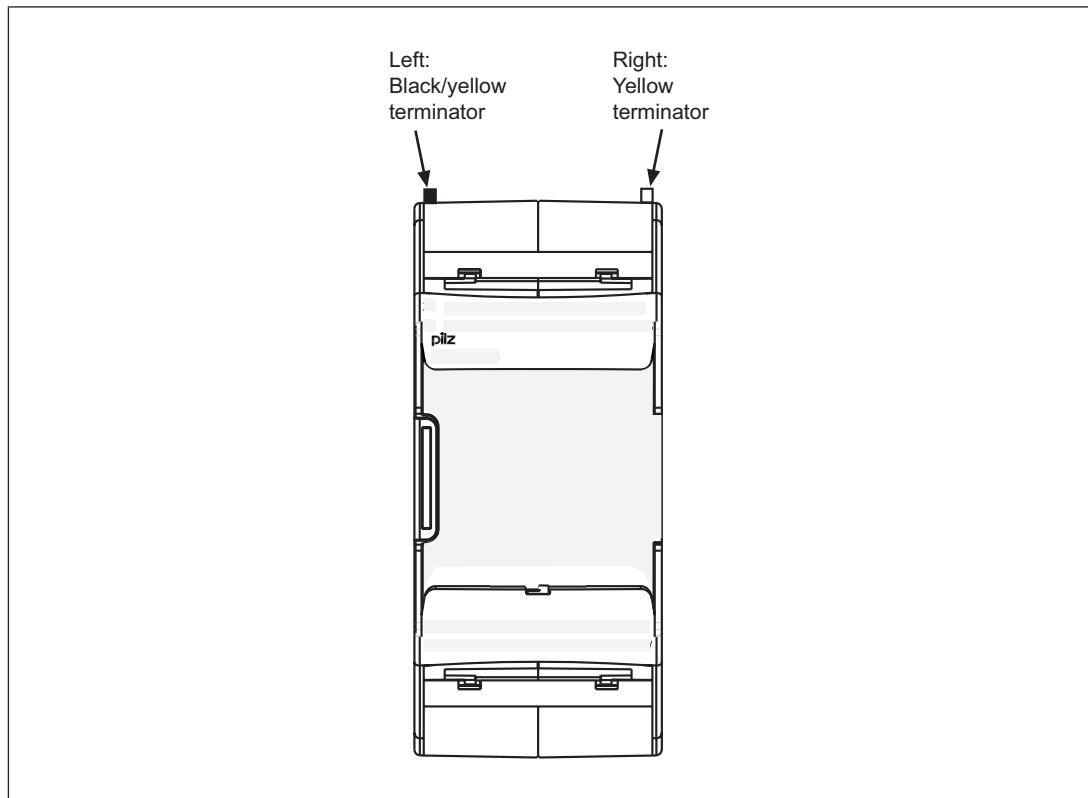

4.3.2 Connect the base unit and expansion modules

The modules are linked via jumpers.

- ▶ Remove the terminator on the side of the base unit and on the expansion module.
- ▶ Before installing the units on the mounting rail, connect the base unit to the expansion module using the jumper supplied .
- ▶ Fit the appropriate terminator to the unconnected interfaces on the base unit and expansion module.
 - Left-hand side on the base unit and expansion modules to the left of the base unit: Black/yellow terminator
 - Right-hand side on the base unit and expansion modules to the right of the base unit: Yellow terminator

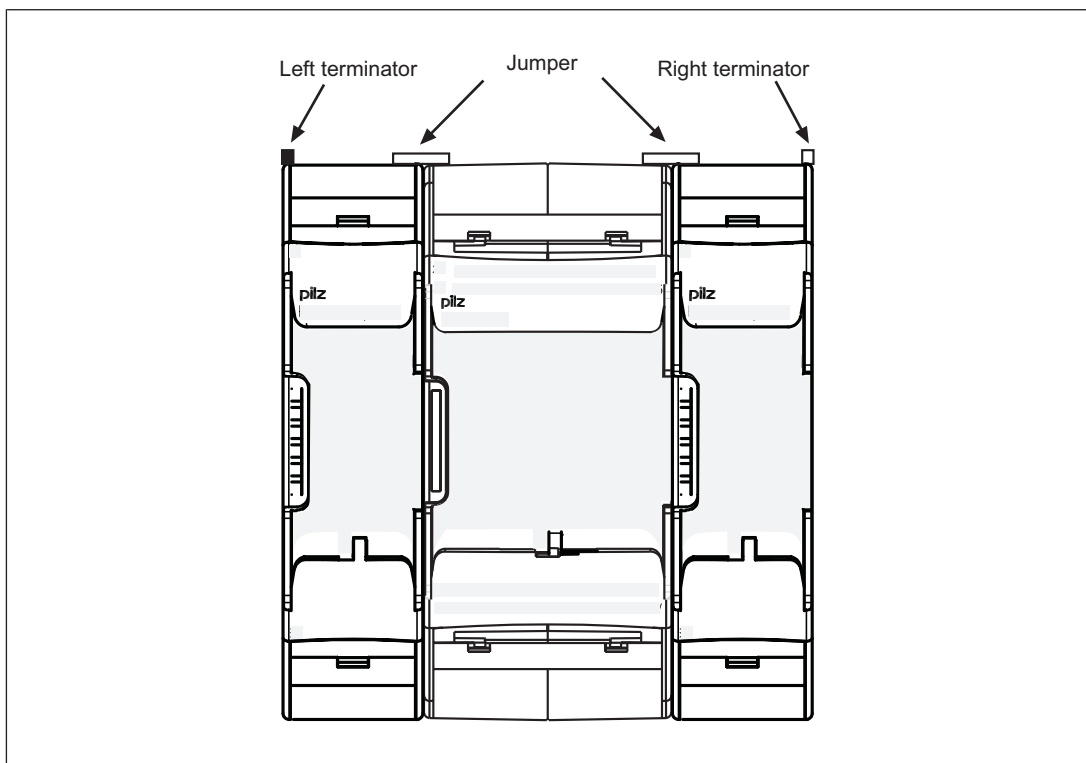

4.4 Install the control system PNOZmulti 2

4.4.1 Install base unit without expansion module

Make sure that the terminators are inserted on the top left and right of the unit.

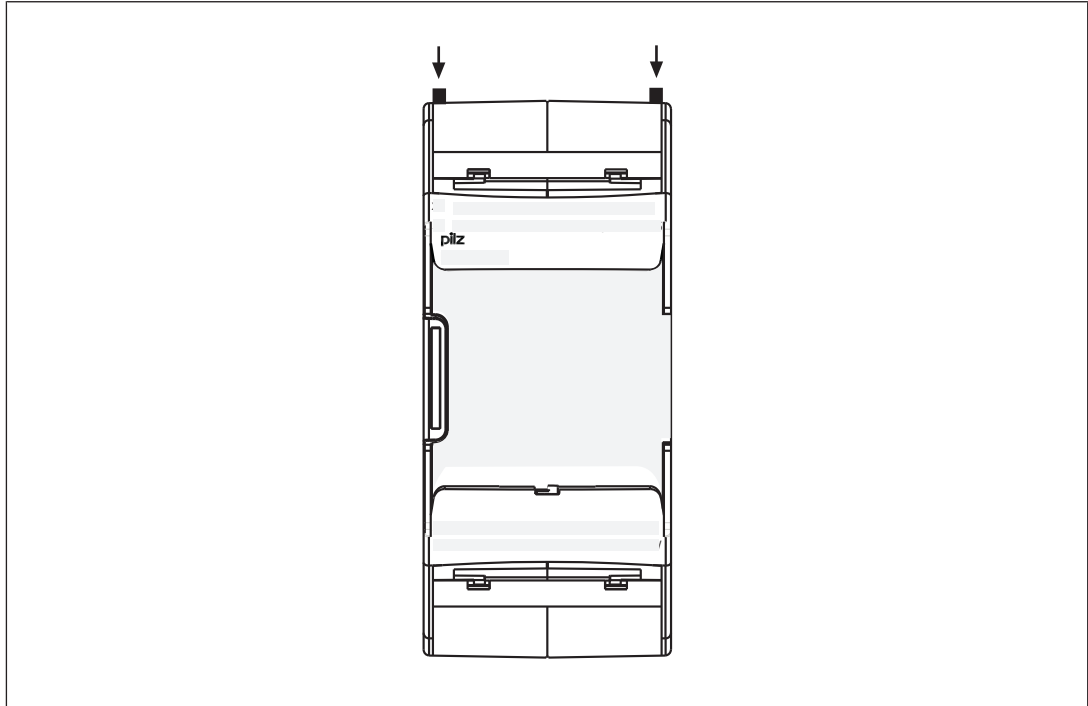

4.4.2 Connecting the base unit and expansion modules

The position of the expansion modules is defined in the PNOZmulti Configurator. The expansion modules are connected to the left or right of the base unit, depending on the type.

Please refer to the document "PNOZmulti System Expansion" for details of the number of modules that can be connected to the base unit and the module types.

The modules are linked via jumpers.

- ▶ Remove the terminator on the side of the base unit and on the expansion module.
- ▶ Install the base unit and expansion modules on the mounting rail in the order configured in the PNOZmulti Configurator and connect the units using the jumper supplied.
- ▶ Fit the terminator to the unconnected interfaces on the base unit and expansion module.

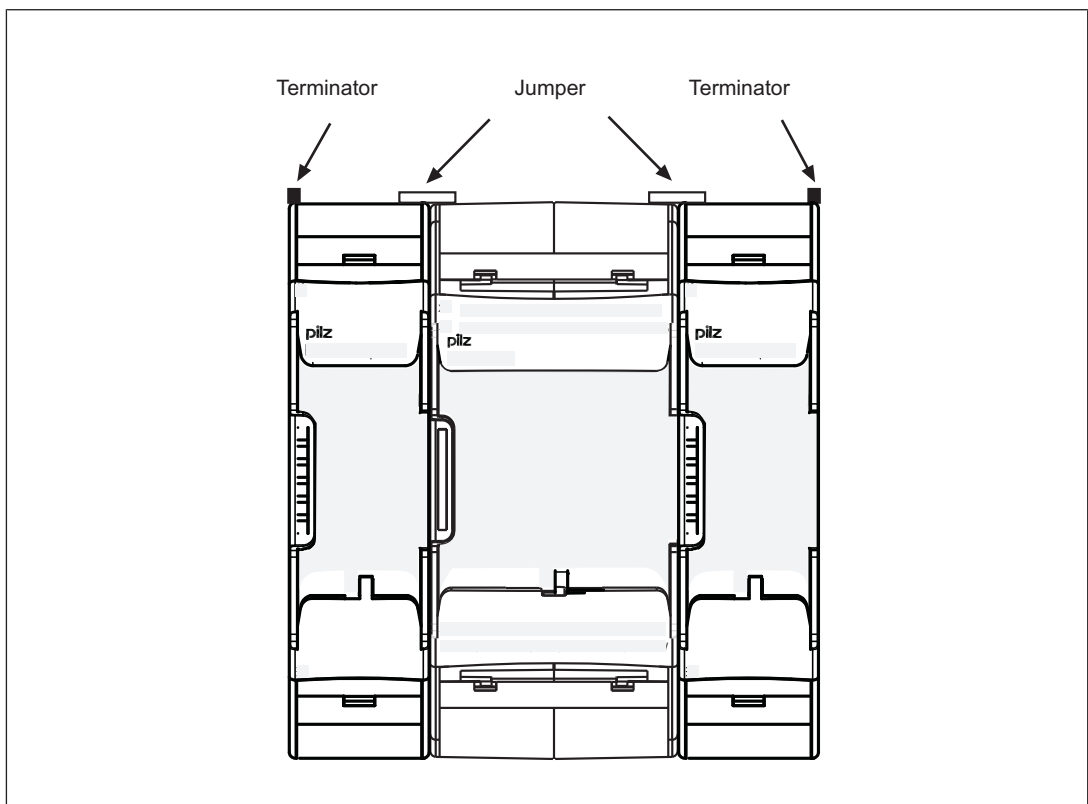

CAUTION!

Only connect the base unit and expansion modules when the supply voltage is switched off.

5 Connecting the Control System PNOZmulti

5.1 General wiring guidelines

The wiring is defined in the circuit diagram in the Configurator.

Note:

- ▶ Information given in the "Technical details" of the respective operating manual must be followed.
- ▶ To prevent contact welding, a fuse should be connected before the relay output contacts (see Technical details).
- ▶ Sufficient fuse protection must be provided on all output contacts with inductive loads.
- ▶ Outputs that are configured as test pulse outputs should only be used to test the inputs (see respective operating manual for details of how to use them). They must not be used to drive loads.
- ▶ Do not route the test pulse lines together with actuator cables within an unprotected multicore cable.
- ▶ Requirements of the fieldbus connection cable: See operating manual for the respective fieldbus module.
- ▶ Separate the supply voltage cable from the analogue input current lines.
- ▶ For transducers located outside the control cabinet: Where the cable enters the control cabinet, the cable shield must be connected to the earth potential over a wide surface area and with low impedance (connect in star).

5.2 Supply voltage

The base units from the configurable control system PNOZmulti require a 24 VDC supply. The connected expansion modules can be supplied with voltage from the base unit via the jumpers.

Different expansion modules (e.g. link modules and analogue input) must be supplied separately (information is available in the expansion module's operating manual).



WARNING!

Risk of electrocution!

Safe electrical isolation must be ensured for the external power supply that generates the supply voltage. Failure to do so could result in electric shock.

The power supplies must comply with EN 60950-1:2006/A11:2009, EN 61558-2-6:11/1997.

To achieve the lowest possible residual ripple ($< \pm 1.2 \text{ V}$), we recommend that you install a three-phase bridge rectifier or regulated supply.

Protect the external power supply by fitting a fuse between the external power supply and the control system. The size of the fuse will depend on the specification of the external power supply, the cable cross section and on local and national regulations.

5.3 Earthing

When units from the configurable control system PNOZmulti are attached to the mounting rail, earthing springs establish the electrical contact between the units' functional earth and the mounting rail. There is no earthing spring on the PNOZmulti Mini. Any connection required to the mounting rail must be established externally (e.g. with the link modules PNOZ mml1p, PNOZ mml2p).

- ▶ Always connect the mounting rail to the protective earth via an earthing terminal. This will be used to dissipate hazardous voltages in the case of a fault.

The mounting rail must be properly earthed to ensure interference-free operation in accordance with EMC regulations.



INFORMATION

Please refer also to the earthing information provided in the chapter entitled "Electromagnetic Compatibility", under "Connecting the earth cables".

Earthing the mounting rail

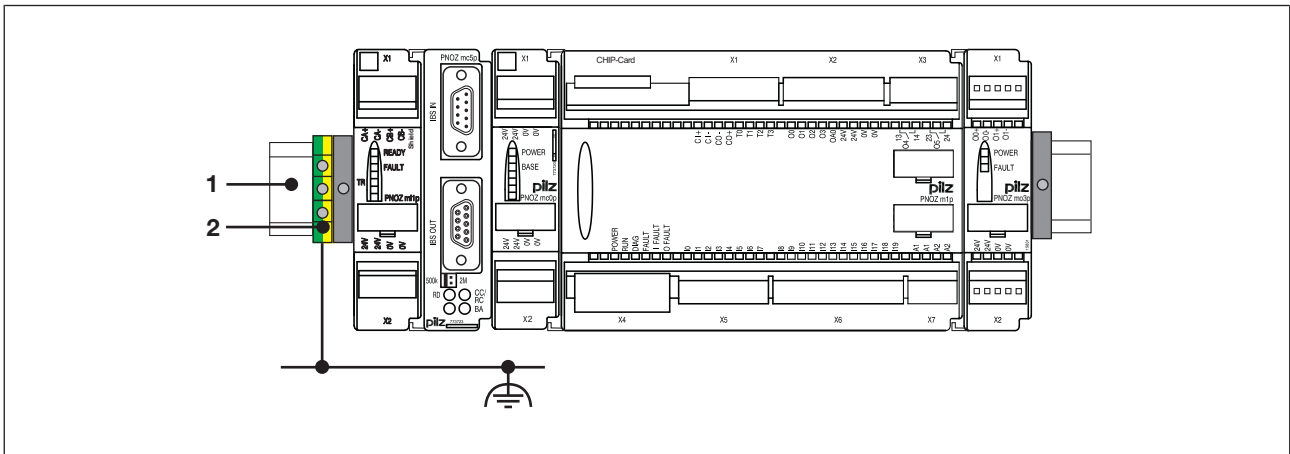

Key:

- ▶ 1: Mounting rail
- ▶ 2: Earthing terminal

5.4 Cable requirements

Configurable safety systems PNOZmulti

Screw terminals:

- ▶ The minimum cable cross section on field connection terminals is 0.5 mm² (AWG22)
- ▶ The maximum cable cross section on field connection terminals is
 - Digital inputs: 1.5 mm² (AWG16)
 - Digital outputs: 1.5 mm² (AWG16)
 - Relay outputs: 2.5 mm² (AWG12)
 - Analogue inputs: 1.5 mm² (AWG16)

- Communication cables: 1.5 mm² (AWG16)
- Test pulse outputs: 1.5 mm² (AWG16)
- Functional earth: 2.5 mm² (AWG12)
- ▶ Torque setting with screw terminals: 0.25 Nm

Spring-loaded terminals:

- ▶ The minimum cable cross section on field connection terminals is 0.5 mm² (AWG22)
- ▶ The maximum cable cross section on field connection terminals is 1.5 mm² (AWG16)
- ▶ Terminal points per connection: 1
- ▶ Stripping length: 9 mm

Configurable compact control systems PNOZmulti Mini, configurable control systems PNOZmulti 2

Screw terminals:

- ▶ The minimum cable cross section on field connection terminals is 0.25 mm² (AWG24)
- ▶ The maximum cable cross section on field connection terminals is 2.50 mm² (AWG12)
- ▶ Torque setting with screw terminals: 0.5 Nm

Spring-loaded terminals:

- ▶ The minimum cable cross section on field connection terminals is 0.2 mm² (AWG24)
- ▶ The maximum cable cross section on field connection terminals is 2.5 mm² (AWG12)
- ▶ Terminal points per connection: 2
- ▶ Stripping length: 9 mm

Please note:

- ▶ Use copper wiring with a temperature stability of 75°C.
- ▶ You must comply with the specifications of the cable manufacturer.

5.5 Terminals

The plug-in terminals for the inputs and outputs are not supplied with the system. You can select between spring-loaded terminals and a screw connection.

Order details can be found in the catalogue or in the operating manual for the respective unit.

5.6 Connecting safety inputs and outputs

In safety-related applications, it is essential that short circuits and open circuits are unable to cause a hazardous condition within the plant.

The way in which this is done will depend on the degree of hazard from the plant section, the switching frequency of the sensors and the level of safety of the sensors and actuators. These points must be assessed in conjunction with the certification body responsible for safety (e.g. BG, TÜV).

Depending on the application area and its respective regulations, the units can be used up to SIL CL 3 of EN 62061 and up to PL e (Cat 4) of ISO 13849-1.

Various tests can be configured for safety inputs and outputs. These tests can be used to detect many short circuits and open circuits. Examples of such tests are:

- ▶ Evaluation of an output's feedback loop
- ▶ Test pulses for detecting shorts between contacts on inputs

Wiring guidelines and connection examples are available in the operating manuals or data sheets for the input/output modules.

5.7 Example of EMC-compliant wiring

The following example illustrates an EMC-compliant connection for a configurable control system PNOZmulti (e.g. PNOZ m1p with expansion modules).

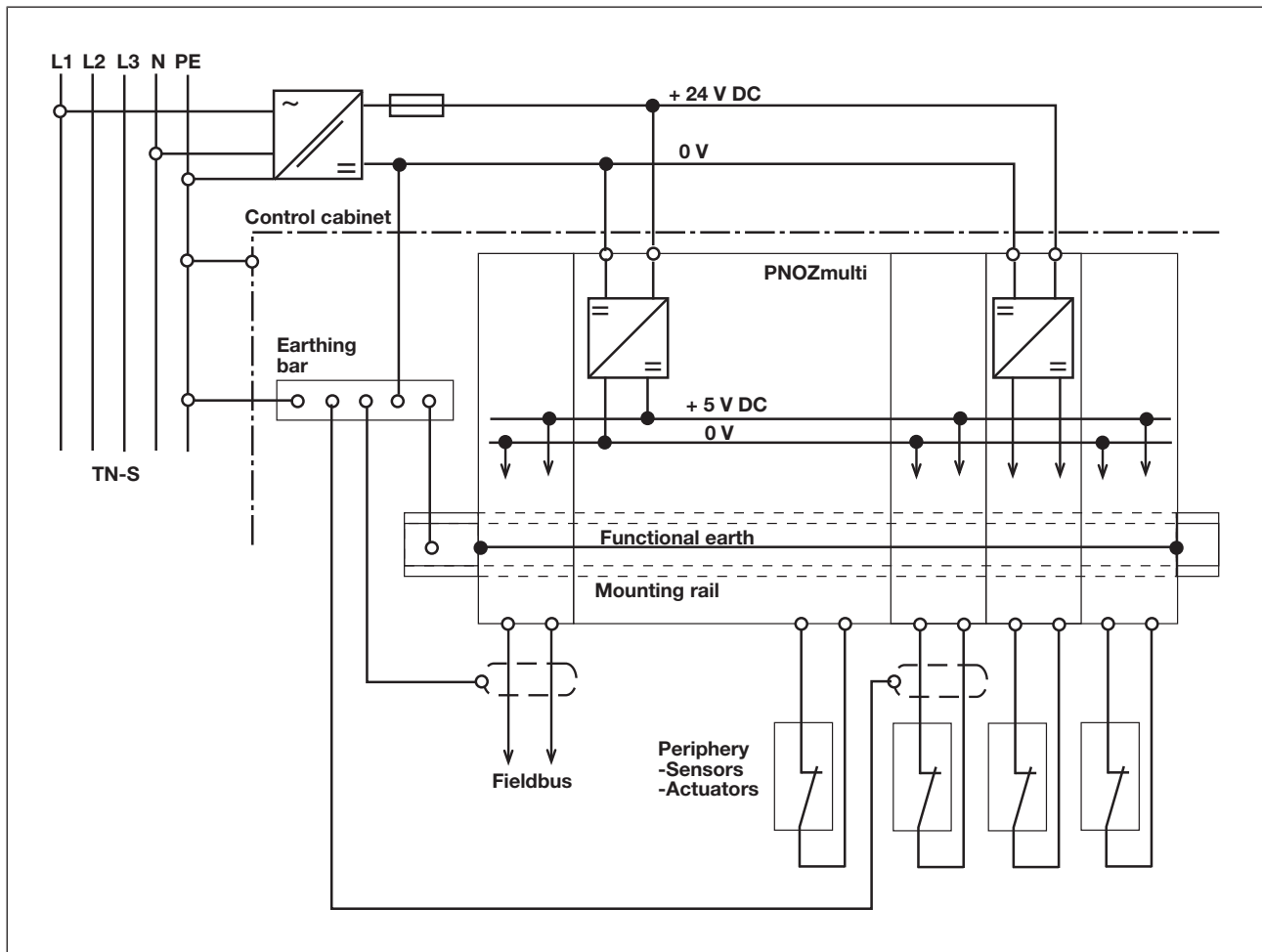

5.8 Analogue input module

Note:

- ▶ Use shielded, twisted pair cable for the connections on the input current circuits.
- ▶ Separate the supply voltage cable from the analogue input current lines.
- ▶ For transducers located outside the control cabinet: Where the cable enters the control cabinet, the cable shield must be connected to the earth potential over a wide surface area and with low impedance (connect in star).

5.9 Motion monitoring modules

Connection technology

- ▶ Proximity switch
 - Plug-in connection terminals (either cage clamp terminals or screw terminals)
- ▶ Encoder
 - Mini-IO socket with motion monitoring modules PNOZ m EF XMM
 - RJ45 socket with speed monitors PNOZ msXp for configurable safety systems PNOZmulti

Please note the following when connecting the encoder:

- ▶ The adapter cable should be as short as possible.
- ▶ A shielded connection box should be used for the sensor signals
- ▶ A separate power supply, isolated from the drive, should be used to supply voltage to the sensors.



INFORMATION

The following applies for the speed monitor PNOZ msXp with RJ45 connection:

The shield connection for the incremental encoder is established via the RJ45 connector housing. Use ready-made cable from Pilz (see units' operating manuals and Technical Catalogue).



INFORMATION

The following applies for motion monitoring modules with Mini-IO connection:

The shield connection for the encoder is established via the adapter cable housing on the drive / inverter.

If necessary, the shielding braid on the adapter cable can be connected to the functional earth via a shield clamp on the mounting rail.

Use ready-made cable from Pilz (see units' operating manuals and Technical Catalogue).

**INFORMATION**

With the RJ45 and Mini-IO plug-in connections, please note that the mechanical load capacity of the data cable and connector is limited. Appropriate design measures should be used to ensure that the plug-in connection is insensitive to increased mechanical stress (e.g. through shock, vibration). Such measures include fixed routing and strain relief, for example:

- A bending radius of at least 5 x the outer cable diameter should be maintained on the cable outlet. However, the cables should be kept as short as possible, taking into account the min. bending radius.
- The cable outlet should be placed face down vertically in order to optimise the connector's contact and stability
- The adapter cable/connection cable should be laid flush so as not to create lateral loads. There should be a lateral offset between the RJ45 / Mini-IO socket and the cable duct.
- Reduce shock and vibration, for example by:
 - separate installation of the control cabinet,
 - floating installation of the control cabinet mounting plate,
 - mechanical decoupling of: mounting plate, control cabinet feet, mounting rail, control cabinet attachment to the machine connection point
 - heavy backplate in the control panel
 - modifying the position of the motion monitoring module in the control cabinet
 - modifying the speed or ramp gradient

**NOTICE**

To avoid EMC interference, note the guidelines provided under [Electromagnetic compatibility \(EMC\)](#) [ 10].

Adapters for encoders

Adapters are available for encoders; these adapters record the data between the encoder and drive and make it available to the motion monitoring module via the RJ45 or Mini-IO female connector.

Pilz supplies complete adapters as well as ready-made cable with female connectors, which can be used when making your own adapter. The range of products in this area is constantly being expanded. Please contact us about the range of adapters that is currently available.

The example below shows a motion monitoring module connected via an adapter.

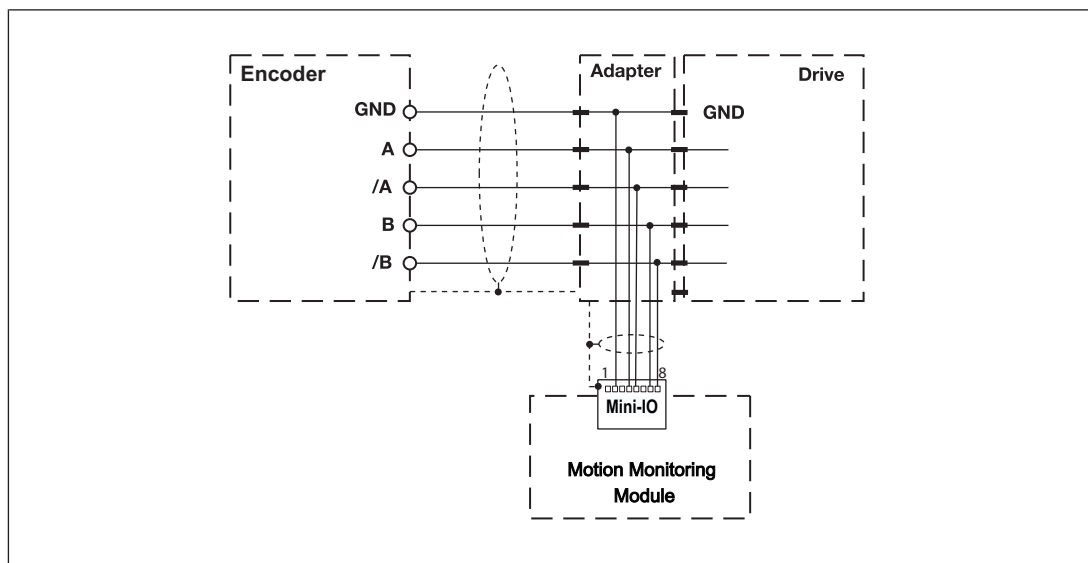

5.10 Connection example: analogue input module and speed monitor

Please note the following guidelines for connecting the shield:

- ▶ Use shielded cable for the input circuit connection cables (6); analogue input circuits should have twisted pair cables.
- ▶ The supply voltage cables (3) should be physically separate from the input circuit cables (6).
- ▶ Where the cable enters the control cabinet, the cable shield must be connected to the earth potential over a wide surface area and with low impedance (connect in star to the shield bar (5)).
- ▶ Appropriate clamps or shield terminals (7) should be used to fasten the shield braid.
- ▶ The shield bar (5) should be connected with low impedance to PE.
- ▶ The shield bar (5) should be connected with low impedance to the earthing terminal (10) on the mounting rail.
- ▶ Route the shield as far as the inputs (4), but leave it unconnected.
- ▶ Metallised RJ45 connector housing (8) with connected shield.

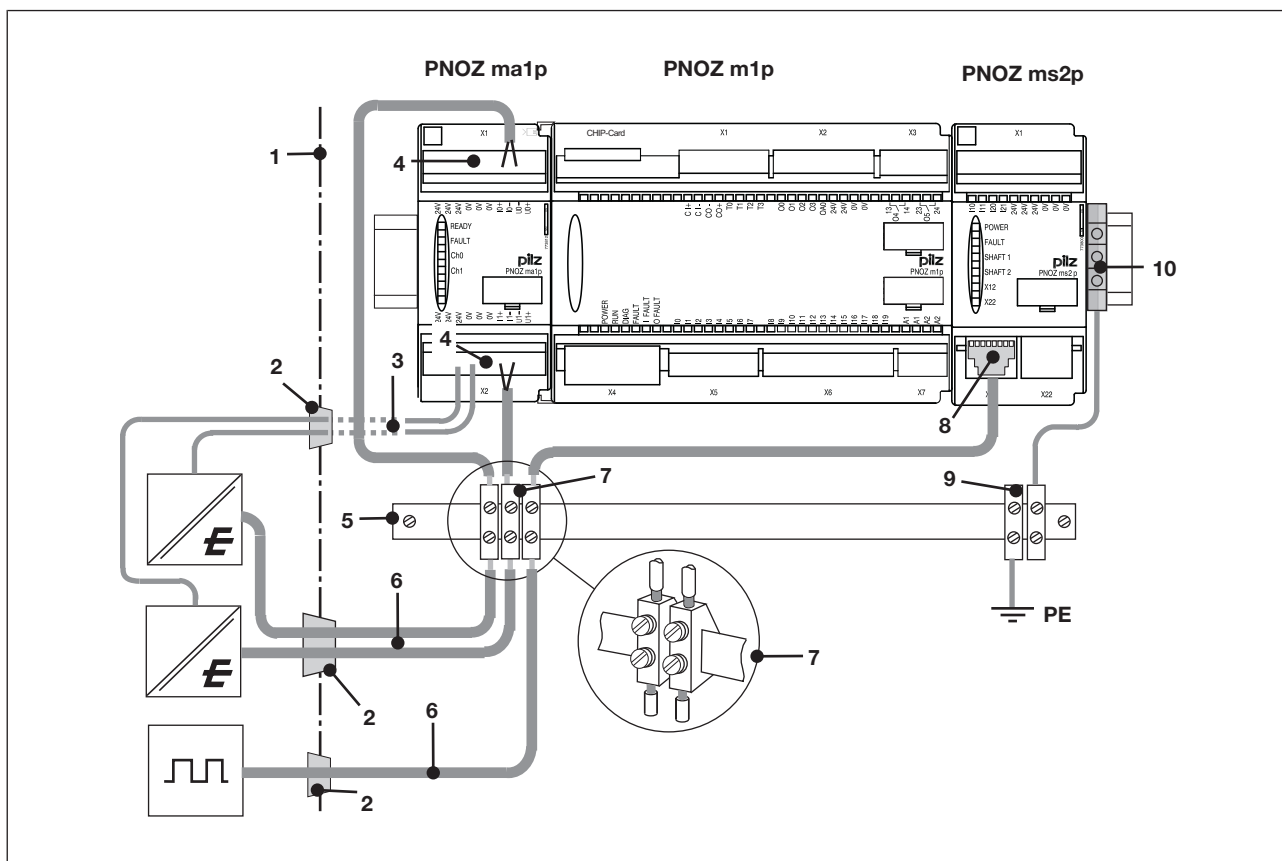

Key:

- ▶ 1: Control cabinet wall
- ▶ 2: Cable bushing
- ▶ 3: Supply voltage for sensors
- ▶ 4: Connections for analogue inputs and supply voltage for sensors
- ▶ 5: Shield bar
- ▶ 6: Sensor signal lines
- ▶ 7: Shielded terminal
- ▶ 8: Metallised RJ45 connector housing with connected shield
- ▶ 9: Terminal for PE
- ▶ 10: Earthing terminal



INFORMATION

When installing, always refer to the guidelines of the sensor manufacturer.

5.11 Fieldbus modules



INFORMATION

When installing the fieldbus modules, please refer to the operating manuals for the respective unit. You should also refer to the guidelines published by the user group or fieldbus manufacturer.

5.12 Link modules

Please note:

- ▶ Information given in the "Technical details" of the operating manuals must be followed.
- ▶ 2 connection terminals are available for each of the supply connections 24 V and 0 V. This means that the supply voltage can be looped through several connections. The current at each terminal may not exceed 3 A.
- ▶ The plug-in connection terminals are optionally designed as spring-loaded terminals or screw terminals (see "Order reference" in the operating manuals).
- ▶ You can use ready-made cable from Pilz to connect the devices.

Cable properties

	PNOZ ml1p <--> PNOZ ml1p	PNOZ ml2p <--> Decentralised modules PDP67	PNOZ mml1p <--> PNOZ mml1p	PNOZ mml2p <--> Decentralised modules PDP67
Max. cable length	Max. 1000 m Version less than 2.0: Max. 100 m	Max. 100 m with shielded cable Max. 30 m with unshielded cable	Max. 1000 m	Max. 100 m with shielded cable Max. 30 m with unshielded cable
Special requirements	4-core shielded, twisted-pair cable Connect shield at both ends, do not connect to the equipotential bonding bar	Allow for the voltage drop on the connection leads (see operating manual)	4-core shielded, twisted-pair cable Connect shield at both ends, do not connect to the equipotential bonding bar	Allow for the voltage drop on the connection leads (see operating manual)
Standards	In accordance with ISO/IEC 11801, minimum Category 5		In accordance with ISO/IEC 11801, minimum Category 5	



WARNING!
Risk of electrocution!

Safe electrical isolation must be ensured for the external power supply that generates the supply voltage. Failure to do so could result in electric shock.

The power supplies must comply with EN 60950-1:2006/A11:2009, EN 61558-2-6:11/1997.

5.13 Cascading

- ▶ Base units from the configurable control system PNOZmulti can be networked. The cascading output on one base unit is connected to the cascading input on another base unit. In this way, one base unit can have direct access to a logic output and/or an input on the connected base unit.
- ▶ The base units can be connected in series or a tree structure can be built.
- ▶ PNOZelog units may also be included in the network.
- ▶ The cascading outputs may not be used to drive loads. The same also applies to outputs on PNOZelog units that are connected to cascading inputs on PNOZmulti units.
- ▶ If necessary, a reset lock must be provided on each cascaded unit.

Example:

- ▶ Delay between input I0 - cascading output Unit 1: 40 ms
- ▶ Delay between input I0 - cascading output Unit 2: 40 ms + 40 ms
- ▶ Delay between input I0 - semiconductor output Unit 3: 40 ms + 40 ms + 40 ms
- ▶ Delay between input I0 - relay output Unit 4: 40 ms + 40 ms + 40 ms + 60 ms

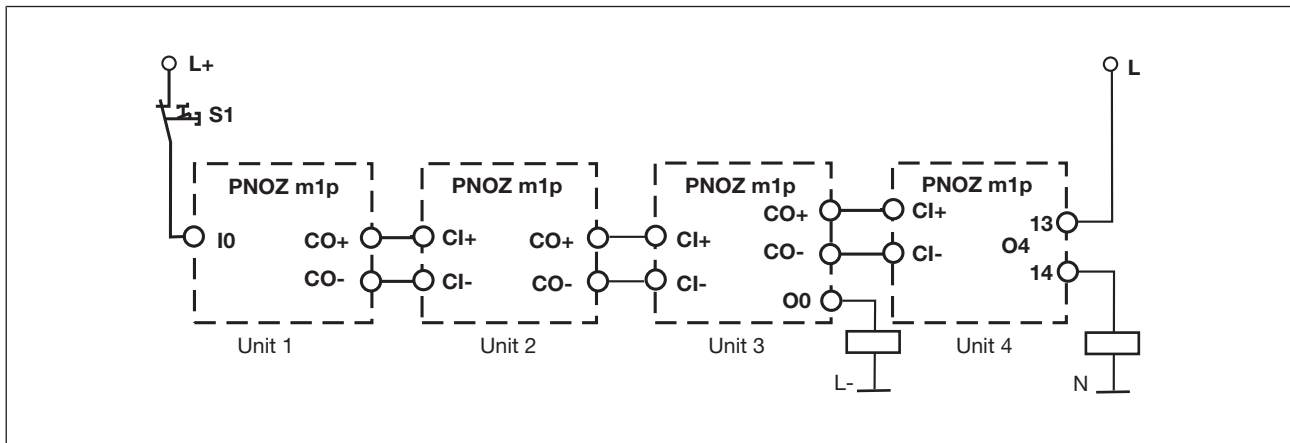

Incorporating PNOZelog units:

- ▶ PNOZelog units may also be included in the series connection. The delay times on the individual units are also added together with this type of cascading.
- ▶ Remember to consider the switch-on delay and any potential delay time for the outputs on the PNOZelog units (see operating manual or PNOZelog technical catalogue).
- ▶ When connecting PNOZmulti - PNOZelog, the cascading output “CO-” is not connected.

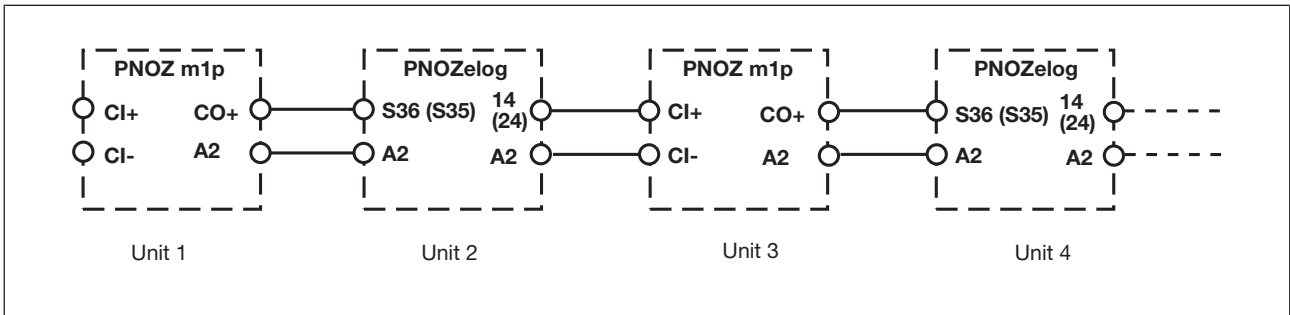

5.13.1 System requirements

PNOZmulti Configurator: from Version 3.0.0

Please contact Pilz if you have an older version.

5.13.2 Series connection

As many PNOZ m1p base units as necessary may be connected in series. The number of units connected in succession will depend only on the reaction time required by the application. As the delay times on the individual units are added together, the reaction time increases with each unit.

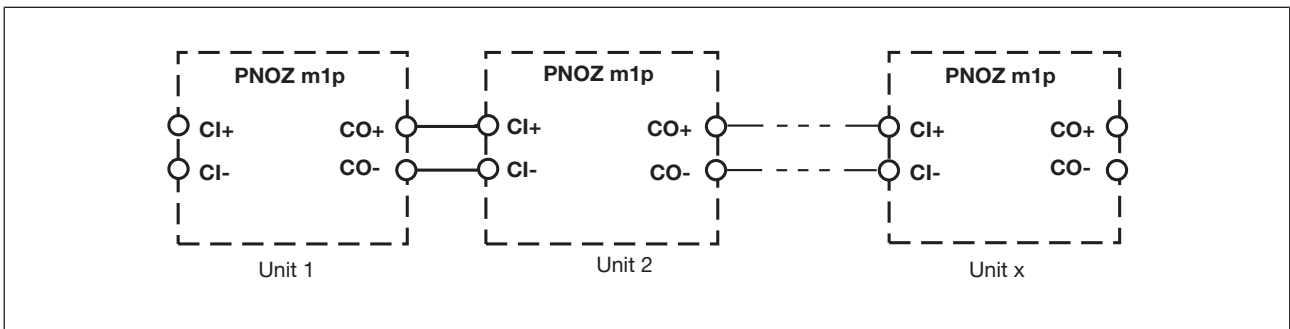

Delay time on the PNOZmulti	Switch-off delay	Switch-on delay
Between input and cascading output	Max. 40 ms	Typ. 100 ms
Between cascading input and a semiconductor output	Max. 40 ms	Typ. 100 ms
Between cascading input and a relay output	Max. 60 ms	Typ. 120 ms
Between cascading input and a cascading output	Max. 40 ms	Typ. 120 ms

5.13.3 Tree structure

- ▶ Tree structures may be designed with as many levels as necessary.

Conditions:

- ▶ A max. of 4 PNOZmulti units may be incorporated in parallel on each level.
- ▶ PNOZelog units may only be connected to the PNOZmulti units in series. Max. of one PNOZelog unit is permitted on each level.

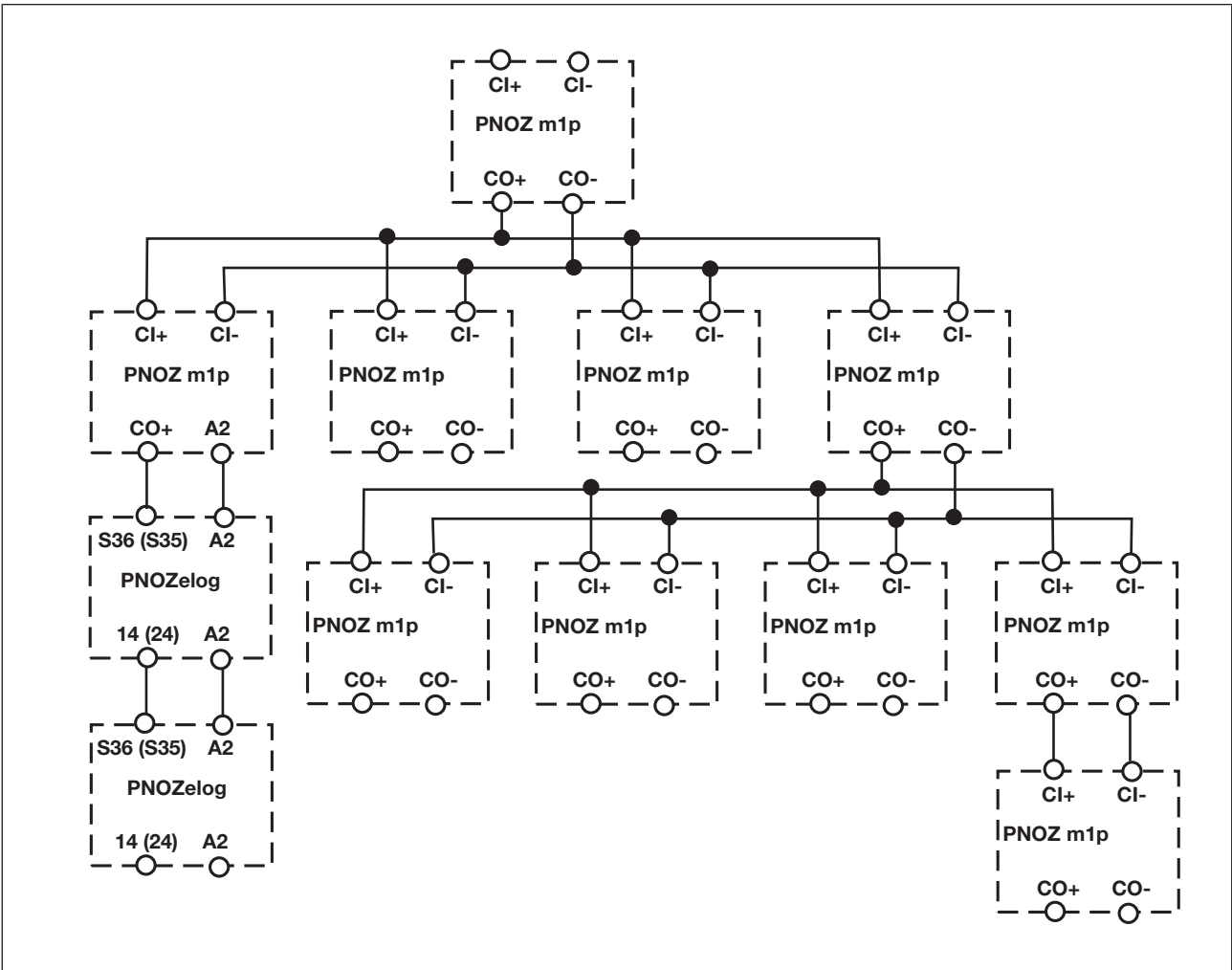

5.13.4 Supply voltage for the cascaded units

- ▶ The cascaded PNOZmulti units may be supplied via a power supply. The power consumption of the individual units should be considered when deciding on the size of the power supply.
- ▶ Cascaded PNOZelog units and all PNOZmulti units connected directly to PNOZelog units must be supplied via a common power supply. The voltage tolerance on the power supply may be a maximum of +20% or -10%.

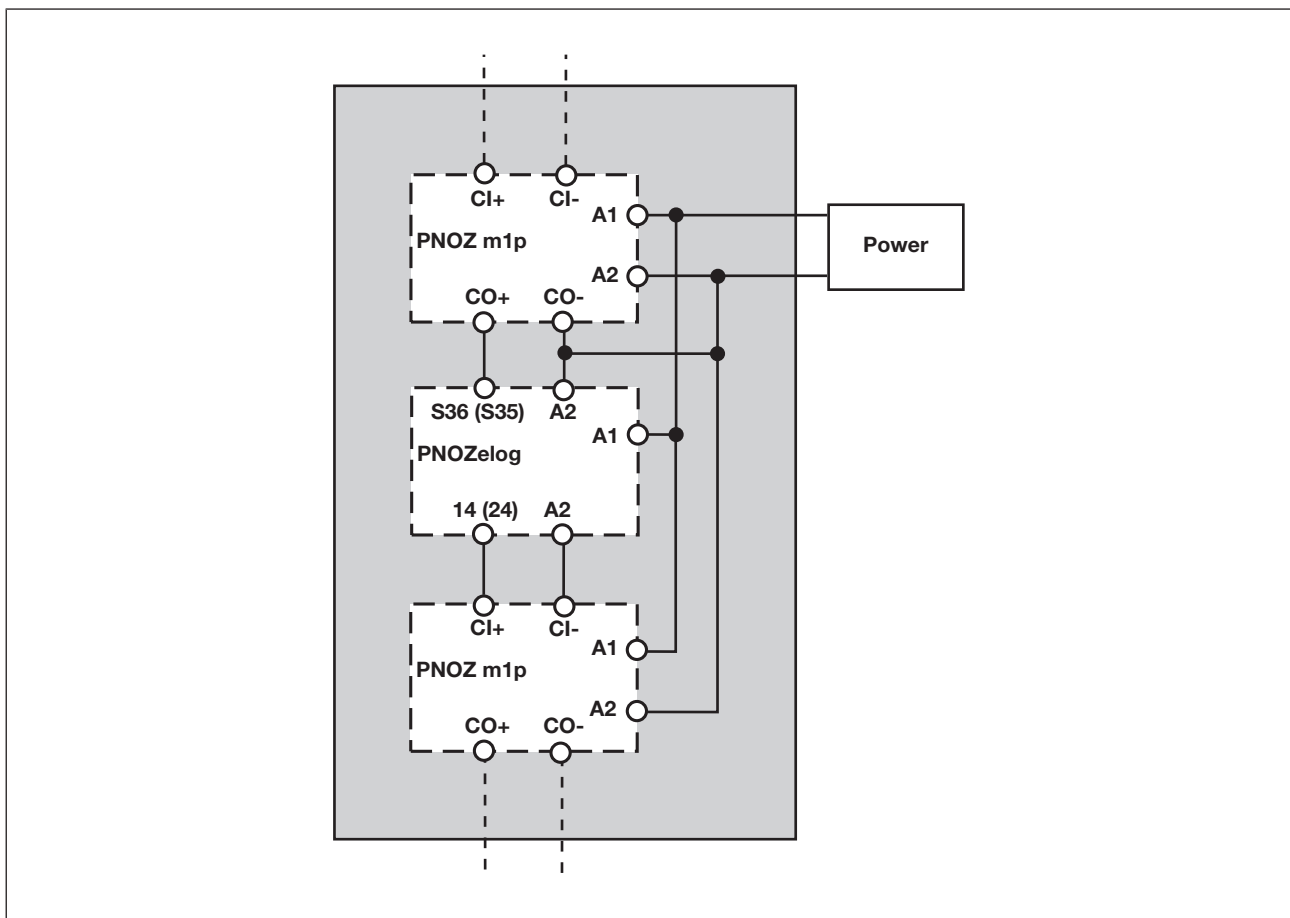

5.13.5 Installing the cascaded units

- ▶ If PNOZmulti units alone are being networked, the networked units may be housed in separate control cabinets.
- ▶ If PNOZelog units are integrated into the network, these PNOZelog units and their cascade cables must always be housed in the same control cabinet as the PNOZmulti units that are connected directly to the PNOZelog units.

5.13.6 Wiring

Please observe the following when wiring:

- ▶ Cable runs between the connected units:
 - PNOZmulti - PNOZmulti: Max. 100 m
 - PNOZelog - PNOZmulti cascaded directly: Max. 10 m
 - Cable material: see Technical details
- ▶ Outside the control cabinet, both the wires from the cascading input (CI+, CI-) and the wires from the cascading output (CO+, CO-) must be laid in separate multicore cables.